

NOBLELIFT

ISO9001 / ISO14001
//2018.04

NEW MODEL RANGE



N Series Electric Forklift



High Speed
& Efficiency



High
Maneuverability



Best Cost-Performance
Ratio

3R 3D 4P
NEW / *Noblelift Forklifts*
ARRIVAL

NOBLELIFT INTELLIGENT EQUIPMENT CO., LTD

www.noblelift.com

N FE4P 4-Wheels Electric Forklift

- Perfect design of outer appearance
- Excellent visibility
- High stability
- Convenient and efficient maintainability
- Excellent ergonomics
- Comfortable configuration and easy operation
- Low noise and low vibration design creating a quiet working environment

1.6-3.5 ton

N series



Excellent ergonomics



High efficiency and low energy consumption



Excellent visibility



Rear hand holder with horn function (option)



High efficiency and low energy consumption

Standard DC voltage converter

The standard DC voltage converter equalizes the use of batteries to extend battery life;

The AC power system has high efficiency and complete protection functions, equipped with speed sensor and temperature sensor, greatly improving its reliability and life.

Electric forklift special pattern tire (optional)

Electric special pattern tires save energy more than 10%.



Working aisle width:
 Pallet size 1000*1200
 16-18:3161mm
 20:3583mm
 25:3588mm
 30:3985mm
 35:4055mm
 Pallet size 800*1200
 16-18:3361mm
 20:3713mm
 25:3718mm
 30:4115mm
 35:4185mm



Climbing performance,
 fully laden/unladen S2 30mins: 13/15



Maximum mast height: :
 1.6-2.0: 6000mm
 2.5-3.5: 6500mm



▶ Reliability and safety

Motor controllers, contactors, power plugs, emergency switches, instrument panels, accelerators etc. all from world famous brand manufacturers;

Advanced AC high-frequency MOSFET integrated controller and CANBUS data bus technology;

High-frequency MOSFET integrated controller ensures smooth and accurate driving and lifting control as well as excellent speed control performance; Excellent match between motor and controller, with functions such as regenerative braking, reverse braking, ramp down ensuring safety and reliability;

Operational sequence protection and controller self-protection.

▶ Low noise and low vibration design to create a quiet working environment

Cushioning device installed at many critical parts such as motor and battery, along with optimized structure to reduce the vibration of forklift;

Load sensing steering gear and the low noise pump ensures lower level of noise;

The speed of descent will automatically slow down before the forks touch the ground; gentle contact with the ground will greatly reduce the collision noise;

The rear axle adopts a flexible damping system, which effectively overcomes road surface clutter and enhances the comfort level of drivers.



Travel speed, full laden/unladen:

16-18: 13/15(Km/h)

20-25: 13/14(Km/h)

30-35: 12/13(Km/h)



Lifting speed, full laden/unladen:

16-18: 0.32/0.42(m/s)

20-25: 0.31/0.40(m/s)

30-35: 0.30/0.39(m/s)



Turning radius:

16-18: 1820mm

20-25: 2050mm

30: 2230mm

35: 2300mm



Right hydraulic operating handle



Beautiful arc design



Convenient and efficient maintainability



Foot pedal parking brake system

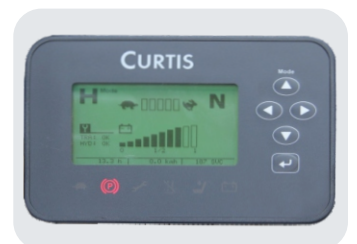

Big LED display



Noblelift intelligent factory

CURTIS instrument

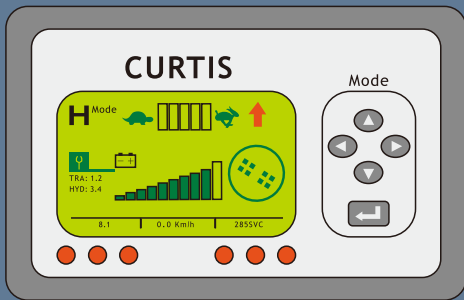

Noblelift N series forklift is equipped with standard CURTIS instrument, mainly to serve for auxiliary control function and provide driver vehicle condition through display interface. It consists of a control circuit, a cumulative time counter (LED), a battery fuel gauge, fault code display and other display circuits.

A brand-new design is made in the control circuit and the display form according to the current electric vehicle demand, providing the driver with the intuitionistic vehicle status information, compact structure, artistic and generous outer appearance, high degree of automation as well as reliable quality.



Noblelift Headquarters

Noblelift North America Corp.

NOBLELIFT



Official website

N FE3D 3-Wheels front drive Electric Forklift

- 48V AC drive system
- Full dual front wheel driving
- Curtis intelligent computer control system and fault display
- Excellent safety and reliability
- Convenient and efficient maintainability
- Intelligent open structure chassis and battery access door
- Ergonomic design and comfortable operation

1.6-2.0 ton

N series

Driving speed,
fully laden/unladen:
16-18:14/15(Km/h)
20:13/15(Km/h)

Lifting speed,
fully laden/unladen:
16:0.32/0.42(m/s)
18-20:0.30/0.42(m/s)

AC

48V AC drive system

Full AC system design uses two AC drive motors and one AC hydraulic motor. High performance is achieved at minimal cost. AC motors do not require inspection or replacement of motor brushes or contactors, which greatly reduces the overall daily frequent maintenance costs. Compared with traditional DC motors, AC motors have higher operating efficiency, longer service life and longer running time. The power-saving feature improves the forklift's ability to run for longer periods of time without compromising productivity or performance.

Turning radius:
16-18:1550mm
20:1680mm

Working aisle width:
Pallet size 1000*1200:
16:3122mm
18:3127mm
20:3257mm
Pallet size 800*1200:
16:3322mm
18:3327mm
20:3457mm

Climbing performance,
fully laden/unladen S2 30mins:
16-18:15/20
20:13/18

Maximum mast height:
6m





Easy service and maintenance access

The N Series offer ages-spring-assisted battery hood to make battery checks and maintenance easier to perform. Downtime is further reduced through the use of its Curtis-board self-diagnostic system that makes troubleshooting and repairs quick and simple. The controller is housed within a compartment designed to prevent the entry of dust, water and other possible contaminants, yet the cover can be removed for easy and quick service and maintenance.



Intelligent open chassis and battery access door

3D N series offers various ways of removing or replacing battery, which is convenient for continuous shift operation and opening of battery door. You may change the battery from side or lift the battery from the battery just as regular forklift.



Ergonomic design and comfortable operation



Excellent safety and reliability



Big LED display



Full dual front wheel drive

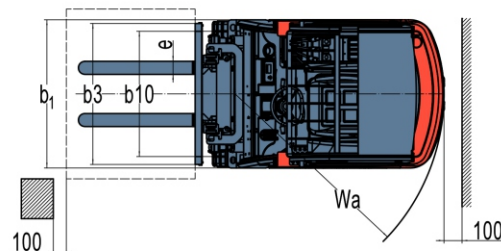
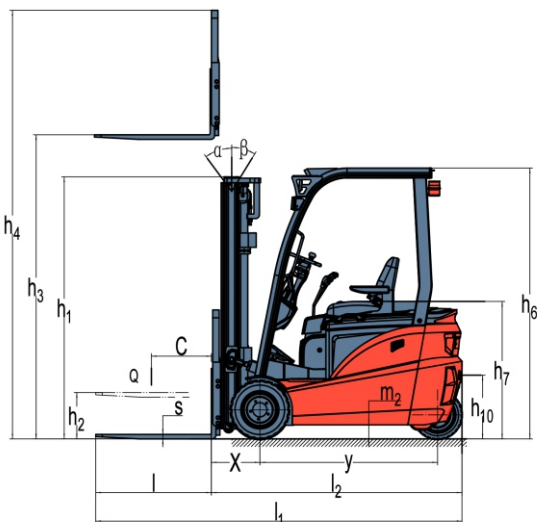

N FE3R 3-Wheels Rear drive Electric Forklift

- Variable wheelbase design, minimizing turning radius
- Compact body design with excellent trafficability
- Curtis intelligent computer control system and fault display
- Excellent safety and reliability
- Convenient and efficient maintainability
- Intelligent open structure chassis and battery access door
- Ergonomic design and comfortable operation

1.6 ton

N series

Noblelift's new N series electric forklifts include the FE3R series of compact three-point rear-drive electric forklifts, the FE3D series three-point front drive counterbalanced electric forklifts, and the FE4P series four-point front drive counterbalanced electric forklifts. N series electric forks with excellent performance will greatly reduce operating costs while boosting your work efficiency. Noblelift is committed to meeting customer needs as well as the concept of energy conservation and environmental protection in material handling industry.



Driving speed, fully laden/unladen:
10/11(Km/h)



Lifting speed, fully laden/unladen:
0.24/0.37(m/s)



Turning radius:
1520mm



Working aisle width:
Pallet size 1000*1200 :3288mm
Pallet size 800*1200:3411mm



Climbing performance,
fully laden/unladen S2 30mins:10/13



Maximum mast height:
6m





Variable wheelbase design

The forward and backward motion of front wheels is realized through the tilting of mast, therefore minimizes the turning radius.



Compact chassis

Overall width of forklift is 1000mm and turning radius is 1520mm, ensuring the excellent trafficability.



Side extraction battery design

Fast change of battery.



Full open cover

Convenient maintenance and repair.

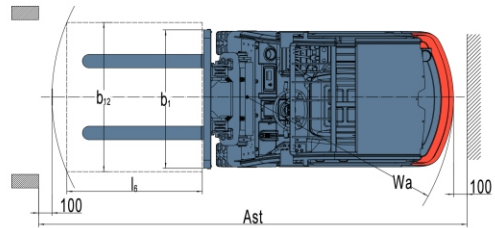
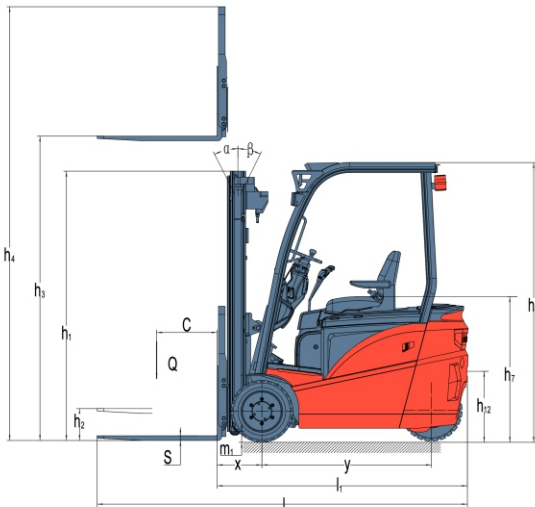

Intelligent factory

